



KrystalMet Software for Material Testing - KRYSTAL -

Batch Details

Client... GOVIND SALES AGENCY

Batch... GFRP ROCKBOLT 25 MM

Operator... S. ROY

Date of Test... 07 June 2021 : 16:32

Sample Details

Test Type... Tensile

Material... GFRP

Specimen... Rod

Sample No... 1

Sensor... Encoder

Test Parameters

Gauge Length... 125 mm
Outer Diameter... 25 mm
Area of C/S... 490.88 mm²

Final Parameters

Gauge Length... 125 mm
Outer Diameter... 24.9 mm
Area of C/S... 486.96 mm²

Load Vs Displacement

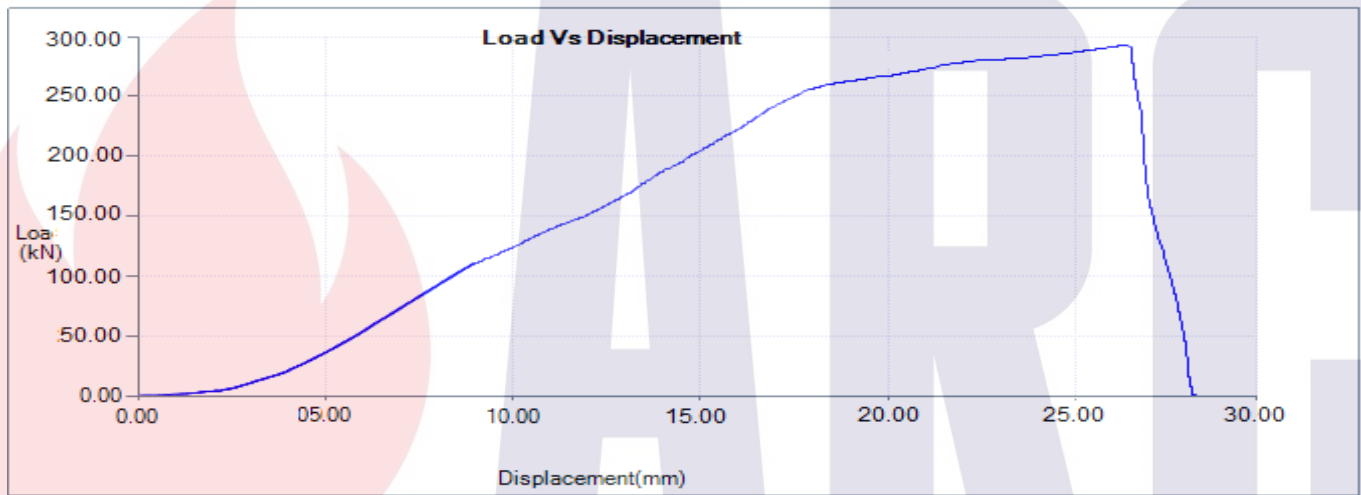

Test Results (Yield calculations by Graph method)

Max. Force (Fm)... **287.48 kN**
Displacement Fm... **27.5 mm**
Stress at Fm... **585.64 MPa**
Strain at Fm... **0.232**
Maximum Displacement... **29.2 mm**
Tensile Strength (UTS)... **585.64 MPa**
Gauge Elongation... **0.1 mm**

Remarks : **Sample Accepted**

Tested By

Verified By

Authorised By

Tested On: ARC INSULATION & INSULATORS PVT.LTD., Sr. No.2010-1020

KrystalMet:V4R7 - Software for Material Testing - © KRYSTAL





KrystalMet Software for Material Testing - KRYSTAL -

Batch Details

Client... L&T MUMBAI COASTAL ROADWAYS

Batch... GRP ROCKBOLT 38 MM

Operator... S. ROY

Date of Test... 20 APRIL 2021 : 17:42

Sample Details

Test Type... Tensile

Material... GRP

Sample No... 1

Specimen... Rod

Sensor... Encoder

Test Parameters

Gauge Length... 190 mm
Outer Diameter... 38 mm
Area of C/S... 1134.12 mm²

Final Parameters

Gauge Length... 190.1 mm
Outer Diameter... 37.9 mm
Area of C/S... 1128.16 mm²

Load Vs Displacement

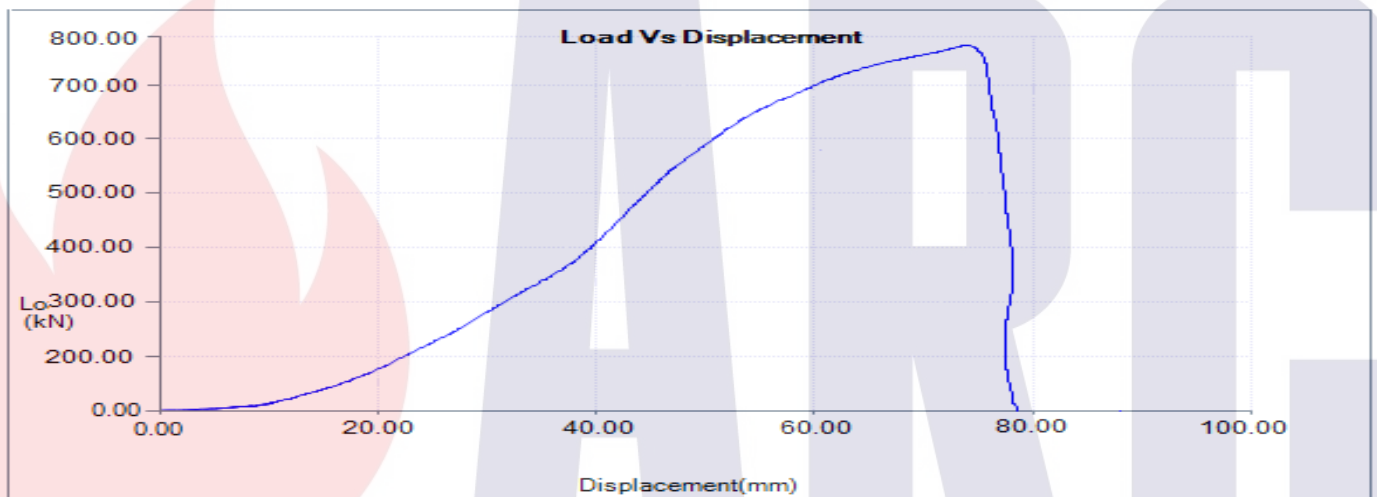

Test Results (Yield calculations by Graph method)

Max. Force (F_m)... **783.59 kN**
Displacement F_m... **75.3 mm**
Stress at F_m... **690.92 MPa**
Strain at F_m... **0.232**
Maximum Displacement... **79.7 mm**
Tensile Strength (UTS)... **690.92 MPa**
Gauge Elongation... **0.1 mm**

Remarks : **Sample Accepted**

Tested By

Verified By

Authorised By

Tested On: ARC INSULATION & INSULATORS PVT.LTD., Sr. No.2010-1020

KrystalMet:V4R7 - Software for Material Testing - © KRYSTAL



ASSY. TEST OF GFRP ROCK BOLT WITH NUT & BEARING PLATE

(Accordance to BS 7861)

A. Apparatus:

A testing machine that can be operated at constant rate of cross head motion i.e. Universal Testing Machine.

B. Test Specimen:

The Test Specimen shall be a GFRP Rock Bolt of 600 mm Length, FRP Nut & FRP Bearing Plate Sq. Type 150x150x8 mm, one MS Plate.

C. Procedure:

The specimen shall be clamped in the serrated jaws of a tensile testing machine. The jaws shall grip the entire faces of the end pieces and the specimen shall be in axial alignment with the direction of pull. Apply an increasing load and record the corresponding extension values.

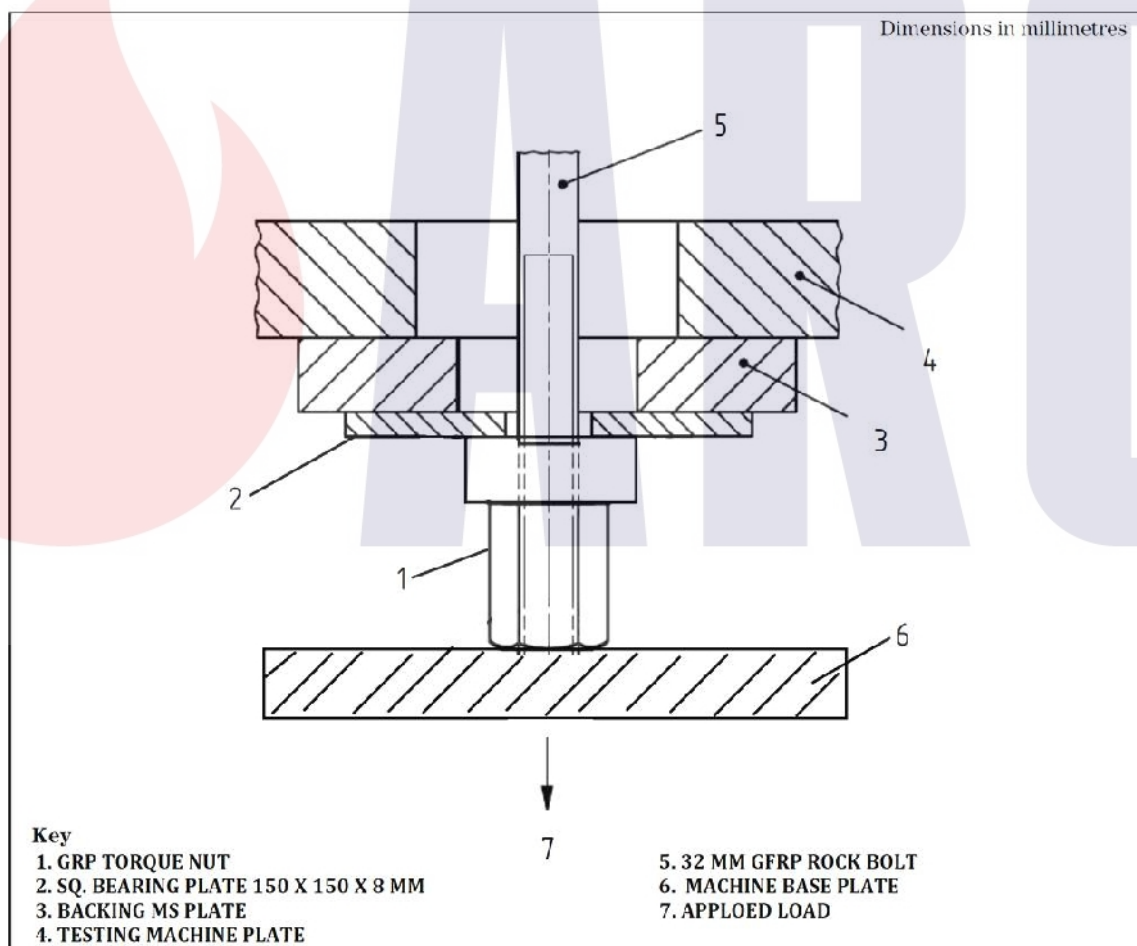

D. RESULT:

Record the maximum tensile load, the load at which pulls through of the assembly occurs.



KrystalMet Software for Material Testing - KRYSTAL -

Batch Details

Client... INHOUSE (DILIP BUILDCON)

INV NO.: 049/22-23

Batch... ASSY TEST OF GFRP ROCK BOLT 32 MM

Operator... S. ROY

Date of Test... 4 July 2022 : 14:39

Sample Details

Test Type... Compression

Material... GFRP SQ BEARING PLATE 150 X 150 mm thk 8 mm

Sample No... 1

Specimen... Other

Sensor... Encoder

Test Parameters

Area of C/S... 0.0225 mm²

Load Vs Displacement

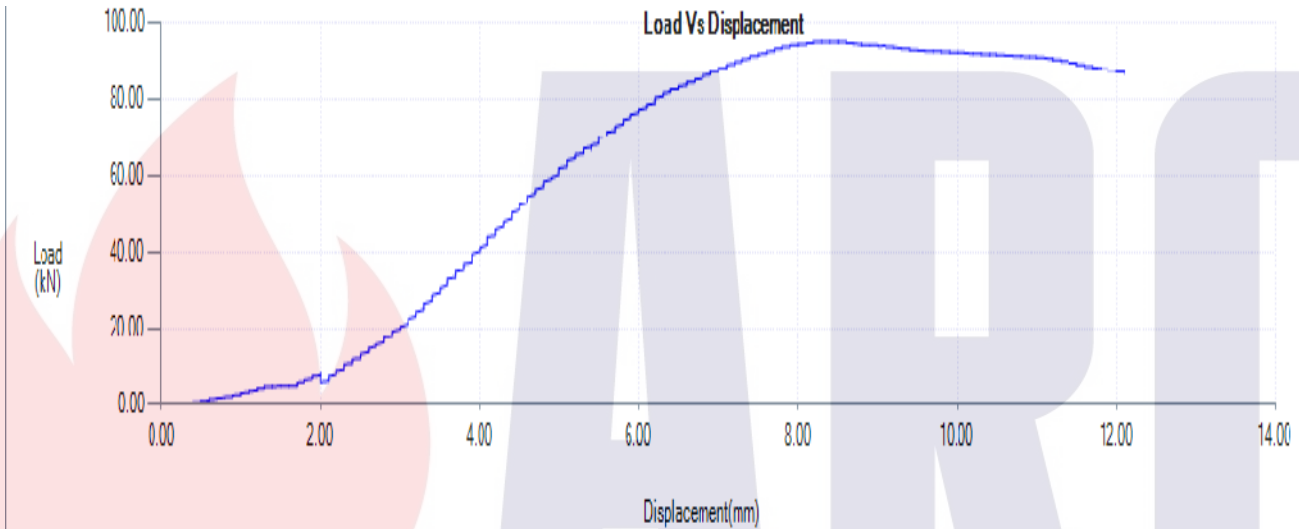

Test Results

Max. Force (Fm)... **95.37 kN**
Displacement at Fm... **8.3 mm**
Maximum Displacement... **12.1 mm**
Compression Strength... **4335000 MPa**
Energy Under Load- **650.692 J**
Displacement Curve...

Remarks : Sample Accepted



Tested By

Verified By

Authorised By

Conclusion:

GFRP Nut has been slipped upward at maximum load but the FRP Sq. Bearing plate won't be broken. Hence the selected FRP Sq. Bearing Plate of 150 x 150 x 8 mm shall be adequate to meet the load capacity of 95.37 KN.

Tested On: ARC INSULATION & INSULATORS PVT.LTD.,UTK-60E, Sr. No.2010-1020

KrystalMet:V4R7 - Software for Material Testing - © KRYSTAL



Testing Photographs

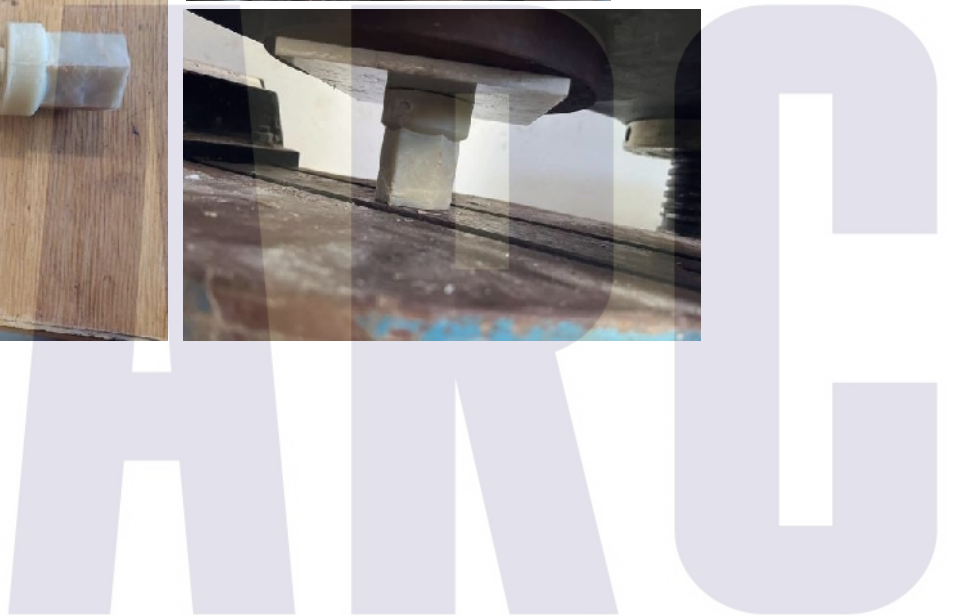
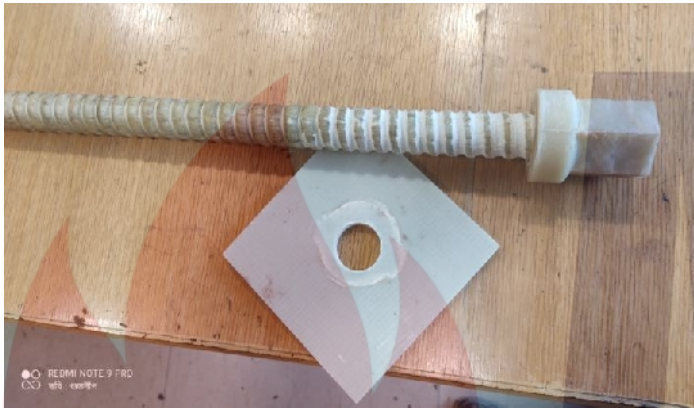
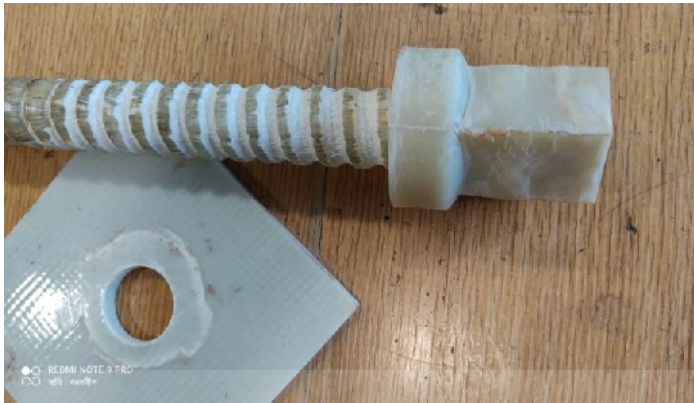



KrystalMet Software for Material Testing - KRYSTAL -

Batch Details

Client... INHOUSE TESTING (DILIP BUILDCON)

INV NO.: 049/22-23

Batch... HOLLOW BAR 32 (160622R32H)

Operator... S. ROY

Date of Test... 16 June 2022 : 15:04

Report No.: ARC/QC/22-23/JOB-53/33

Sample Details

Test Type... Tensile

Material... GFRP

Sample No... 1

Specimen... Tube

Sensor... Encoder

Test Parameters

Gauge Length... 160 mm
Inner Diameter... 15 mm
Outer Diameter... 32 mm
Area of C/S... 627.533 mm²

Final Parameters

Gauge Length... 160.1 mm
Inner Diameter... 14.9 mm
Outer Diameter... 31.9 mm
Area of C/S... 624.863 mm²

Load Vs Displacement

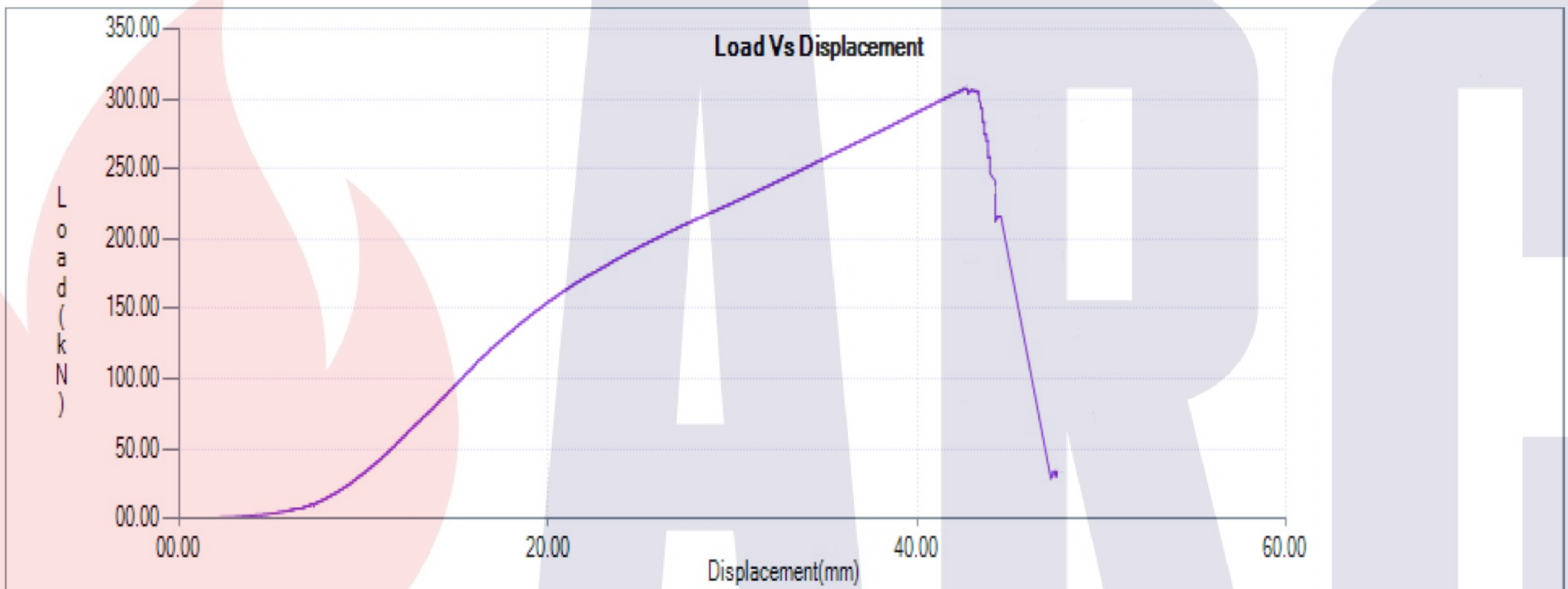

Test Results (Yield calculations by Graph method)

Max. Force (Fm)... **309.56 kN**
Displacement Fm... **42.1 mm**
Stress at Fm... **493.296 MPa**
Strain at Fm... **0.194**
Maximum Displacement... **48.5 mm**
Tensile Strength (UTS)... **493.296 MPa**

Remarks :

Tested By  

Verified By

Authorised By

Tested On: ARC INSULATION & INSULATORS PVT.LTD.,UTK-60E, Sr. No.2010-1020

KrystalMet:V4R7 - Software for Material Testing - © KRYSTAL

